

SPECIFICATION

High Quality Switching Power Adapter

**Universal AC Input
60W 12VDC
Single Output**

P/N: A120050CHL2

**** Specification Approval****

This specification (total 8 pages including cover page) is approved in it's entirety by:

Company Name

Print Name

Signature

Date

Specification subject to change without notice unless prior agreement in place.



Santa Clara CA 95054
Tel: 1-408-980-9813
Fax: 1-408-980-8626
Email: infor@topmicro.com
Web: www.topmicro.com
022411V.1

1. Scope

This document describes basic electrical and mechanical characteristics of a universal AC input, single DC output switching power adapter. It can provide for a continuous 60W max. current at 12VDC and meets international safety and efficiency regulations.

2. Electrical

2.1 Input

2.1.1 Input Voltage Range

Power adapter shall operate within input specification from 90Vac to 264Vac or provide automatic switchover between high line and low line input ranges. The table below shows common input voltage range.

Input Range	Minimum	Nominal	Maximum	Unit
		90 V	100V- 240V	264V

Table 1 - Input Voltage Range

2.1.2 Input Frequency Range

The power adapter shall operate within specification from 47 to 63Hz.

2.1.3 AC Inrush Current

Peak inrush current should not exceed 70A at 240Vac, 50Hz, 25 degrees C, cold start. It should not interrupt line fuse or cause damage to the power adapter either at cold or warm start.

Peak inrush current should not exceed 70A at 100Vac, 60Hz, 25 degrees C, cold start. It should not interrupt line fuse or cause damage to the power adapter either at cold or warm start.

The inrush current must be limited to the extent that no damage is done to the supply under any specified line, load, and temperature conditions. The inrush current shall not cause any external protection devices (i.e. fuses) to trip.

2.1.4 Input Current

Maximum steady state input current shall not exceed 1.7A for any line voltage specified in 2.1.1.

2.1.5 Leakage Current

0.7mA max. at 240Vac.

2.1.6 Insulation Resistance

Insulation resistance shall be more than 100M ohm between primary and secondary.

2.1.7 No Load Consumption

Vin	Load	Power Consumption
240Vac/50Hz 100Vac/60Hz	0A	≤ 0.3W

Note: Complies to EPA standard Version 2.0 Energy Star EPS specification.

2.2 Input Protection

2.2.1 Input Current Protection

A fuse with rating of 4.0A / 250V (time lag type) shall be installed on the input line side near the input connector and no any electrical components before.

2.3 Output

2.3.1 Output Power

The total output power, under steady state conditions, shall not exceed 60W.

Power supply will meet and be tested to IEC60950-1 LPS (Limited Power Source, section 2.5 in the standard) requirements. The LPS designation will be included on the data-plate label.

2.3.2 Output Voltage and Current

Under any combination of line and load variation and environmental conditions, all outputs shall remain within tolerance as defined in Table 2. Output voltage(s) shall be measured at the load side of output connector.

Output Voltage	Voltage Range		Current Range	
	Lower Limit	Upper Limit	Minimum Load	Full rated load
+12.0V	11.40V	12.60V	0A	5.0A

Table 2 - Output Voltage and Current

2.3.3 Ripple and Noise

Measurements shall be made with an oscilloscope with minimum of 20MHz bandwidth and 1:1 scope probe, Output shall be bypassed at the connector with a 0.1 μ F ceramic disk capacitor and a 22 μ F electrolytic capacitor for general testing purpose.

Output Voltage	Maximum Ripple & Noise (Vp-p)
+12.0V	240mV

Table 3 – Ripple and Noise

2.3.4 Over Voltage Protection

The power adapter shall provide with over voltage protection such that under any single component failure.

Output Voltage And Crrnt	Maximum OVP Trip Voltage
+12.0V 5.0A	18.5V

Table 4 – Over Voltage Protection

The power supply provides output over voltage protected in latch off by zener diode, and no damage to customer device.

2.3.5 Over Current Protection

The power supply shall be protected when operating any output in overload condition (set @ max load: 5.8A – 8.80A). The power adapter shall be shut down and no any damage when the over current condition occurs on the output, and It will be auto-recovered when the failure is removed. Input voltage: 100Vac or 240Vac

2.3.6 Overshoot

During turn on or turn off, the output overshoot shall not exceed nominal output voltage by more than 5% and output shall not change its polarity with respect to its return line.

2.3.7 Short Circuit Protection

Power adapter shall have self-limiting protection to protect against short circuit or overload conditions. No damage to the power adapter shall result from a continuous or intermittent short circuit condition. It will be auto-recovered when the failure is removed.

2.3.8 Audible Noise

There is no audible noise can be hear when it work with rated spec.

2.3.9 Limited Power Sources (LPS)

The power supply shall comply with the limited power source requirement as defined in IEC 60950-1 section 2.5 standard.

2.4 Performance

2.4.1 Efficiency

Efficiency shall be a minimum of 87.0% at active average mode, which complies to EPA standard Version 2.0 Energy Star EPS specification.

2.4.2 Turn-On Delay Time

Output shall reach steady state within 3 seconds of turn on at 100Vac or greater.

2.4.3 Hold-Up Time

Hold-up time shall be a minimum of 8mS at 115Vac / 60Hz input.

2.4.4 Dynamic Load

Power adapter shall operate within regulation defined in section 2.3.2 at following conditions:

Step load change: from 50% Load to 100% Load on the output.

Dwell Time: 100Hz & 1 KHz 50% duty.

Slew rate: 0.5A/usec

3. Environmental

3.1 Temperature

Operation: -10 to 40 degrees C

Storage: -20 to 85 degrees C

3.2 Humidity

Operation: 10% to 90% relative humidity, non-condensation.

Storage: 5% to 95% relative humidity, including condensation.

3.3 Vibration and Shock

The power supply shall be designed to withstand normal transportation vibration per MIL-STD-810F, method 514 and procedures X, as it is mounted in the chassis assembly and packed for shipping.

3.4 Altitude

Sea level to 2000 meters.

4. Safety Approvals

Agency	Certification	Countries
UL	UL60950-1(QQGQ,QQGQ7;AZSQ,AZSQ7)	US
cUL	C22.2 No. 60950-1	Canada
CB	IEC-60950-1:2005;IEC 60065:2001+A1	IEC
CCC	GB 4943;GB8898	China
BSMI	CNS13438, CNS14336	Taiwan
GS	EN 60950-1:2006+A11; (A12 soon) EN60065:2002+A1+A11	Germany
IRAM	IEC 60065:2001+A1	Argentina
Australia/New Zealand	AS/NZS 60950.1	Australia/New Zealand

4.1.2 EMI

VCCI Class-B

FCC 15(Class-B, 115Vac operation)

CISPR 22 Class-B limits

EN55022 (1998+A1:2000+A2:2003 Class-B limits)

47 CFR Part 15, Subpart B, Class B limits

EN 61000-3-2 Power line Harmonics

EN 61000-3-3 Flicker Emissions

GB 9254 ITE Emissions Latest Edition

GB 17625.1 Harmonics Latest Edition

4.1.3 Immunity

EN 55024: 1998+A1:2001+A2:2003

Electrostatic Discharge: 61000-4-2

RF Immunity: 61000-4-3

Electrical Fast Transients: 61000-4-4

Surge: 61000-4-5

Voltage Sags and Interrupts: 61000-4-11

Conducted Immunity: 61000-4-6

4.1.4 Environment

RoHS regulation.

The RoHS compliance symbol will be included on the rating label.

4.1.5 Energy Star

EPS complies to EPA standard Version 2.0 Energy Star EPS specification.

TOP will be responsible for meeting the EPA requirements. Including all testing and application. The Energy Star Version 2.0 compliance symbol is to be included on the data-plate.

5. Drawing

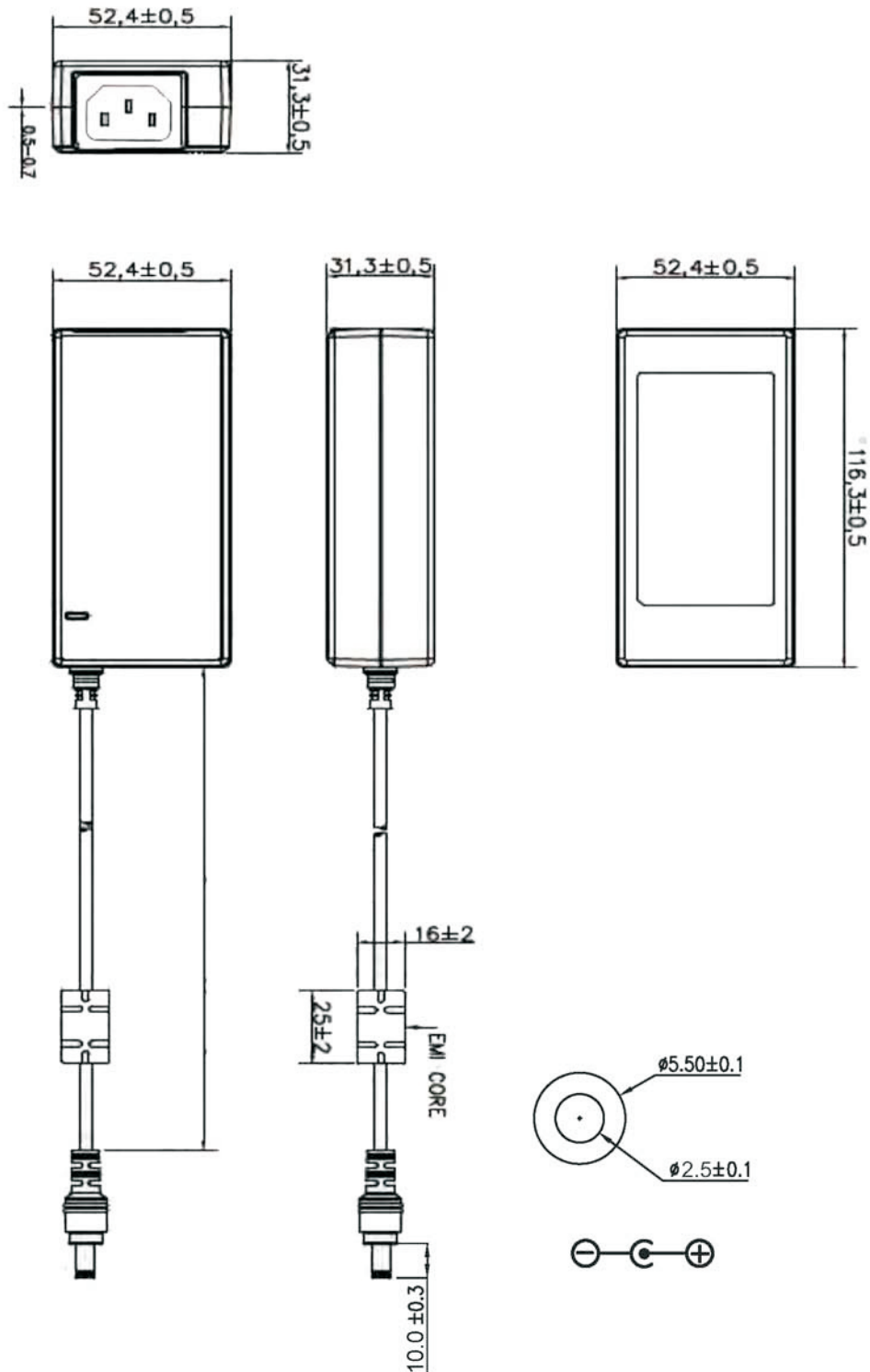

7. Packing

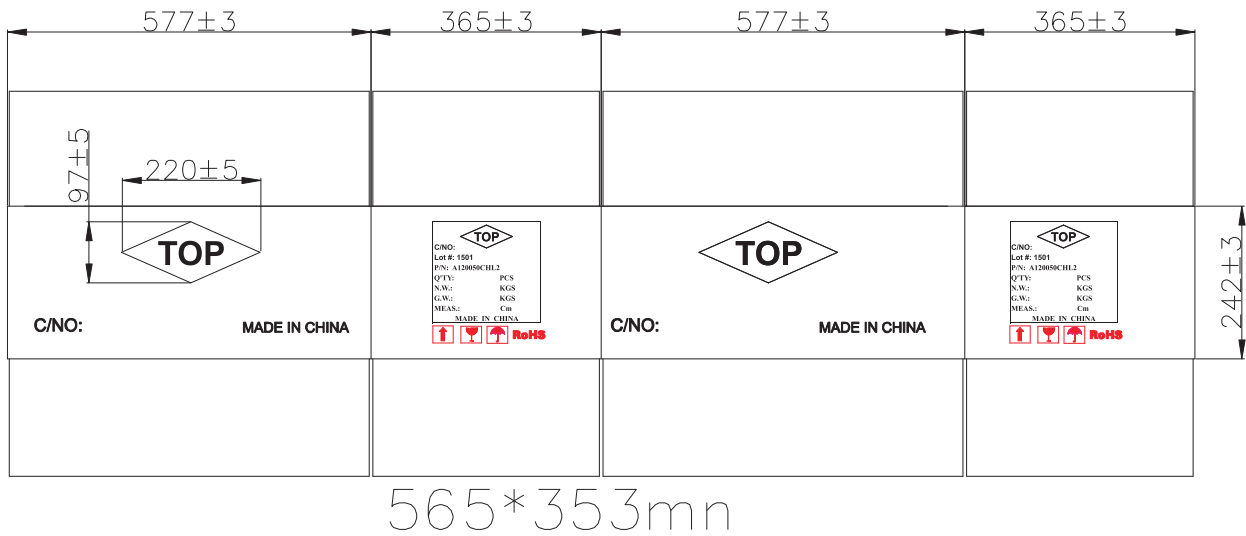

紙箱、隔板、刀卡材質：五層瓦 6mm,破裂強度10KG
 切口處倒角為10mm
 每箱裝2層，36PCS

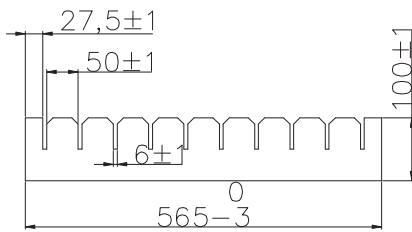

10刀卡 (t=6mm)
 每箱配6PCS

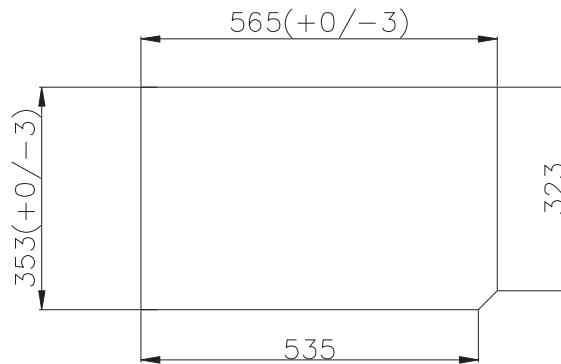

隔板 (t=6mm)
 每箱配3PCS

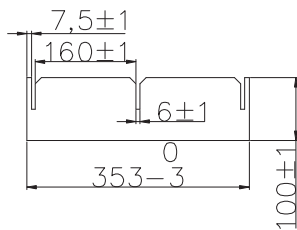

3刀卡 (t=6mm)
 每箱配20PCS

Shipping mark:

