

SPECIFICATION

High Efficiency Linear AC/AC Adapter

**12VAC Input
16.5VDC 1A Output
Efficiency Level VI**

P/N: LA165010D-US

Specification Approval

This specification (including cover page) is approved in it's entirety by:

Company Name

Print Name

Signature

Date



Santa Clara CA 95054
Tel: 1-408-980-9813
Fax: 1-408-980-8626
Email: infor@topmicro.com
Web: www.topmicro.com

1. Part: EI-48
2. Current Diagram:

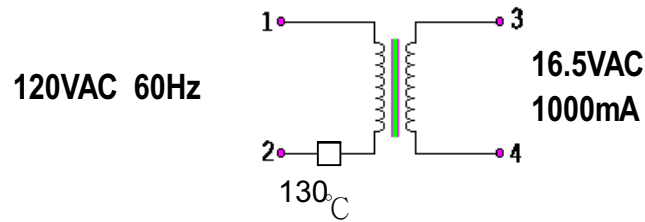

3. Construction:
 - 3.1 Lead tension test: Lead must be withstand a pull 1.5kg for 30 seconds.
4. Characteristics:
 - 4.1 Primary rated voltage and frequency: 120 VAC 60 Hz
 - 4.2 Secondary rating with Tolerance, at Input Voltage 120 VAC, 60 Hz

Rated Voltage	Rated Current	No Load Voltage
16.5VAC \pm 5%	AC 1000mA	24VAC MAX

 - 4.3 Exciting Current: Input Primary 120 V 60 Hz 100 mA MAX.(No Load)
 - 4.4 Hi-Pot test: Apply 1500 VAC 3 mA 60 Seconds between the Primary to Secondary and between Primary to Core.
Apply 500 VAC , 3 mA 60 Seconds between Secondary to core.
Insulation test: 500 V DC 100 M Ω min, between winding to winding and core.
 - 4.5 Humidity test: Temp 25 \pm 5 °C relative humidity 91~95 % RH for 6 hours. After Keeping 30 minutes following insulation must be larger than 5.0M Ω .
 - 4.7 Temperature test: Less than 75 °C for rated test with Resistance method.
5. Applicable Standards: UL/CUL

6. Mechanical Drawing

Enclosure Colour : Black

DC Cord Colour : Black

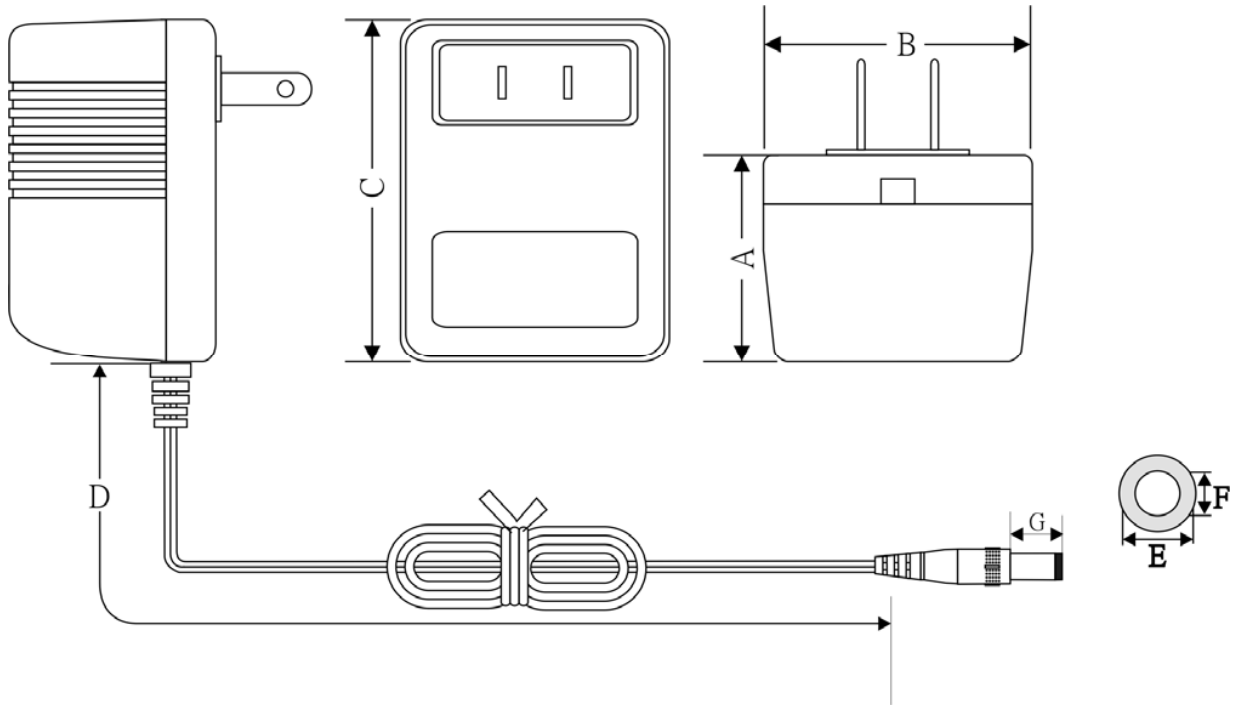

A	47.5±2	B	57.8±2	C	73.8±2	D	1800±100
E	5.5±0.1	F	2.1±0.1	G	11.0±0.5		

7. Parts List

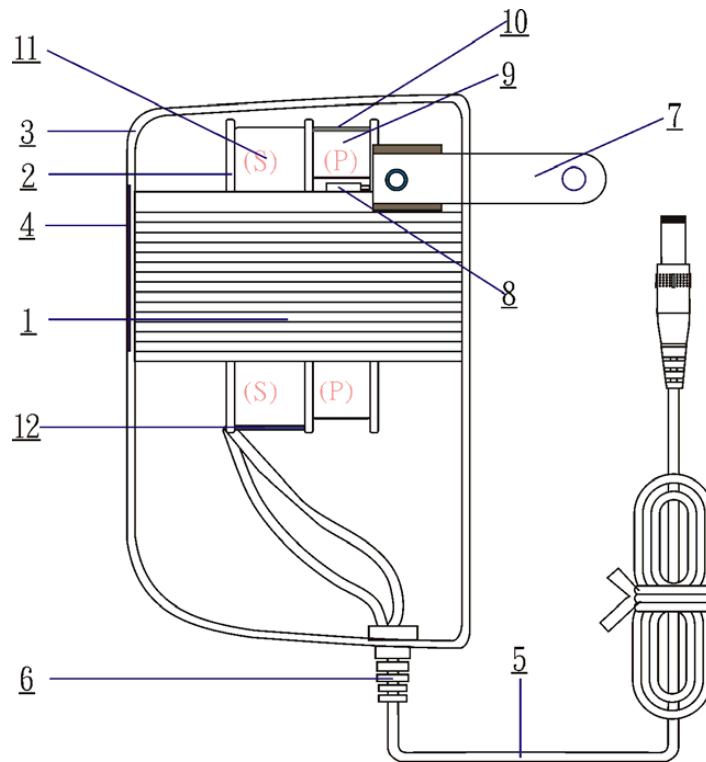

NO	DESCRIPTION	MATERIAL	SPEC & Q'TY	MANUFACTURER
01	Core for ROHS	Silicon Steel	∟ H18	SHANG TU MANUATURE FACTORY OR EQUIVALENT
02	Bobbin for ROHS	N66	1_PCS.	SON KON Plastic & Metal Manufacture OR EQUIVALENT
03	Enclosure for ROHS	ABS or PPO	1_SET.	AS ITEM 01
04	Nameplate for ROHS	PVC (UL/CSA) 0.27mm Thick	1_PCS.	JIE SHENG PRINT CO.,LTD OR EQUIVALENT
05	Output Cord for ROHS	UL2468 AWG22 Plug :5.5*2.1*9.5 mm	1_PCS.	SHENG SEN WIRE CO.,LTD OR EQUIVALENT
06	Strain Relief for ROHS	PVC.	1_PCS.	AS ITEM 05
07	Blade for ROHS	Nickel plating Copper 1.45mm Thick	1_PCS.	AS ITEM 01
08	Thermal Cutoff Fuse. for ROHS	130°C 250V 2A	1_PCS.	WANG LI CO.,LTD OR EQUIVALENT
09	The Primary Winding for ROHS	Polyurethane Enameled Copper Wire		WING TAI ELECTRONIC MATERIAL FACTORY LTD OR EQUIVALENT
10	The Primary Insulation. for ROHS	Polyester Tape. Press Board	0.05mm 2_Turns. 0.25mm 1_PCS.	YA HUA STICKING TAPE CO.,LTD OR EQUIVALENT
11	The Secondary Winding. for ROHS	Polyurethane Enameled Copper Wire.		AS ITEM 09
12	The Secondary Insulation for ROHS	Polyester Tape.	0.05mm 2_Turns. 0.05mm ___Turns.	AS ITEM 10

8. Packing Information

Q'TY:36PCS

N.W:19.6KGS

G.W:20.6KGS

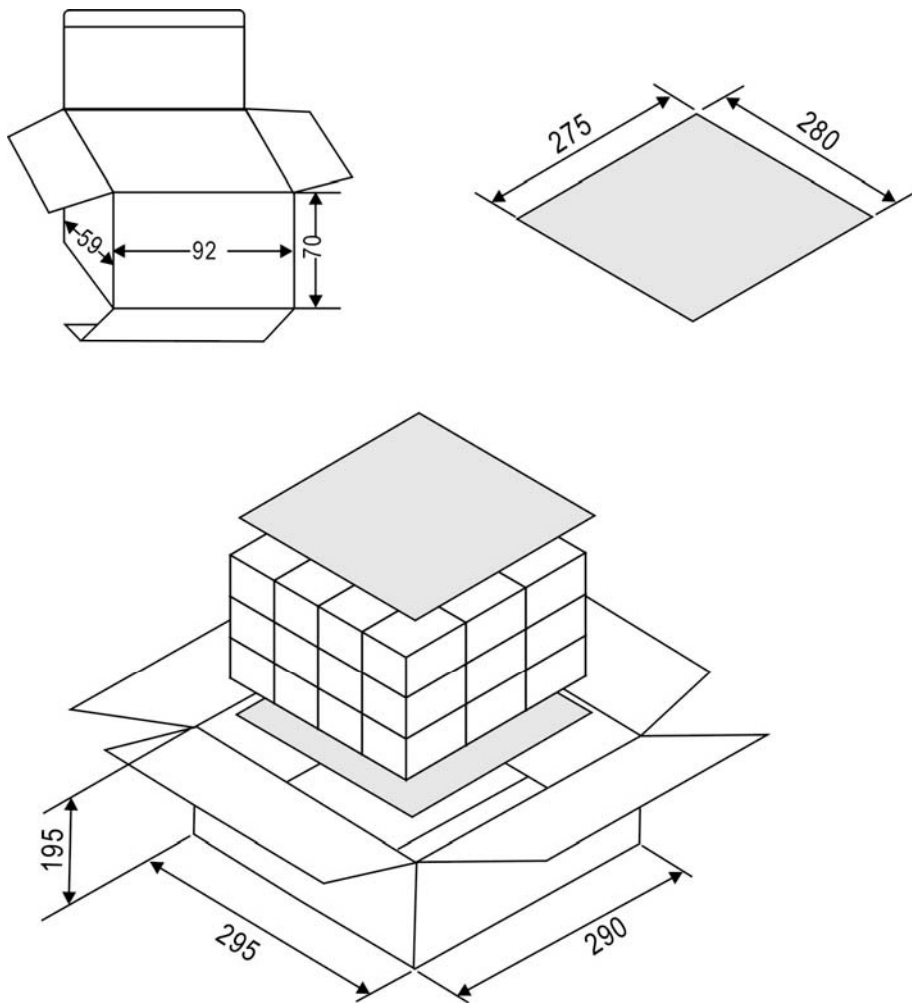

9. Rating Label

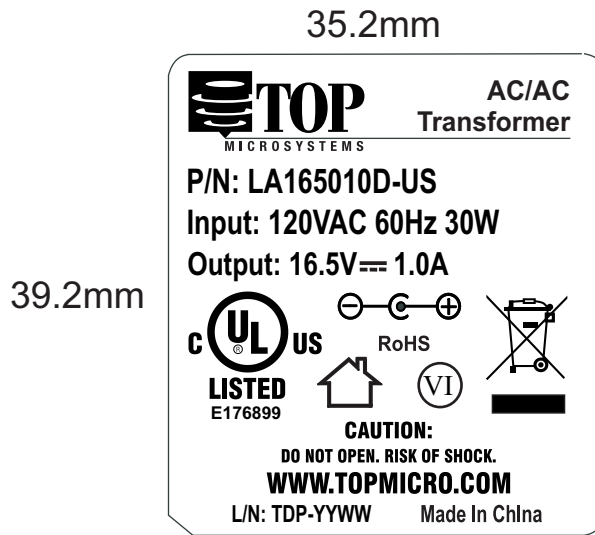

Material: P.V.C., 0.27mm, fireproof