

SPECIFICATION

Switching Desktop Adapter Efficiency Level VI

**Universal AC Input
42W 12V 3.5A Output**

P/N: A120035GPL

**** Specification Approval****

This specification (including cover page) is approved in it's entirety by:

Company Name

Print Name

Signature

Date



Santa Clara CA 95054
Tel: 1-408-980-9813
Fax: 1-408-980-8626
Email: infor@topmicro.com
Web: www.topmicro.com
101910V1.0

1. Input

- 1.1 Rate input voltage: 100-240VAC
- 1.2 Vibration input voltage range: 90-264VAC
- 1.3 Rate input frequency: 50/60Hz
- 1.4 Vibration rate input frequency: 47/63Hz
- 1.5 AC input rated current: 1A Max. @ 100VAC
- 1.6 Max. consumption (no-load): 0.75W Max. @ 230VAC
- 1.7 Inrush current: 60A Max. @ 100VAC cold start
90A Max. @ 230VAC cold start
- 1.8 Leakage current: 0.25mA Max.

2. Output

- 2.1 Rating output voltage: 12V
- 2.2 Rating output current: 3.5A
- 2.3 Min. load current: 0A
- 2.4 Output no-load voltage: 12V±5%
- 2.5 Output load voltage: 12V±5%
- 2.6 Output ripple & noise: 250mV

3. General

- 3.1 Max output power: 42W
- 3.2 Efficiency: 88% Min.
- 3.3 Short circuit protection: Protection against short circuit for output.
The output can be shorted without damage.
- 3.4 Overshoot / undershoot: 12V±10%
- 3.5 Switching frequency: 60 KHz Typical
- 3.6 Any protect condition shall cause no damage and no component fail.
Automatic recovery when removal of protect condition.

4. Environmental

- 4.1 Operating temperature: 0°C to 40°C
- 4.2 Storage temperature: -25°C to 85°C
- 4.3 Operating relative humidity: 8% to 90%
- 4.4 Storage relative humidity: 5% to 95%

5. EMI Standard

FCC Class B, CE

6. Hi-pot

- 6.1 Primary to secondary: 4525VDC for 3 secs.
- 6.2 Primary to case: 4525VDC for 3 secs. 5mA

7. Insulation resistance

- 7.1 Input to output: >10Mohm. @ 500VDC

8. Reliability

- 8.1 Burn-in: 2 hrs, 40°C +/-5°C, 240VAC
ON/OFF cycling full load nominal line
- 8.2 Altitude: Will operate properly at altitude between 0 to 6000ft.

9. Mechanical

- 9.1 Bending test: 1000times, Swings 120^b Left to right loading
weight 200 g, 40 cycle/minute; 2400 cycles.
- 9.2 Pull test: DC cord and plug, weight 9kg for 1 minute.

10. DC Cable and Plug

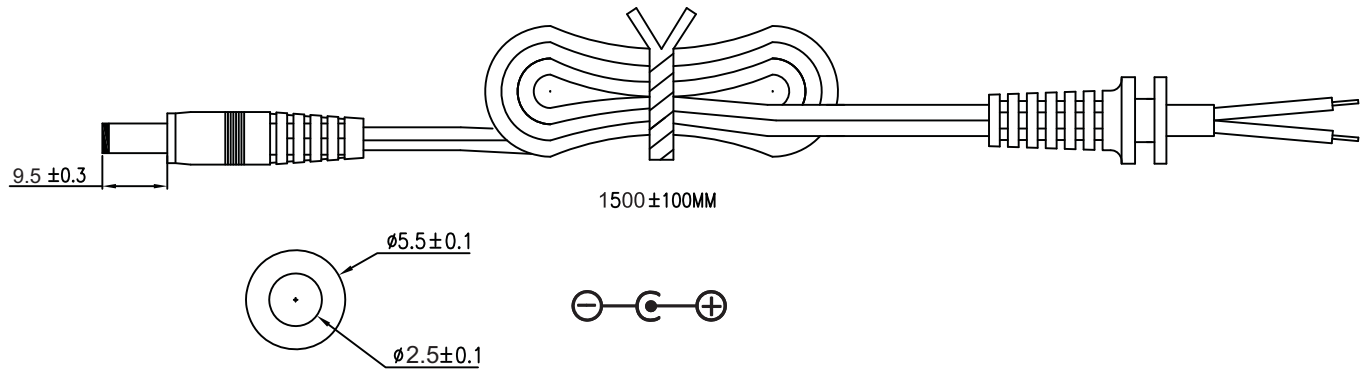

11. Mechanical Drawing

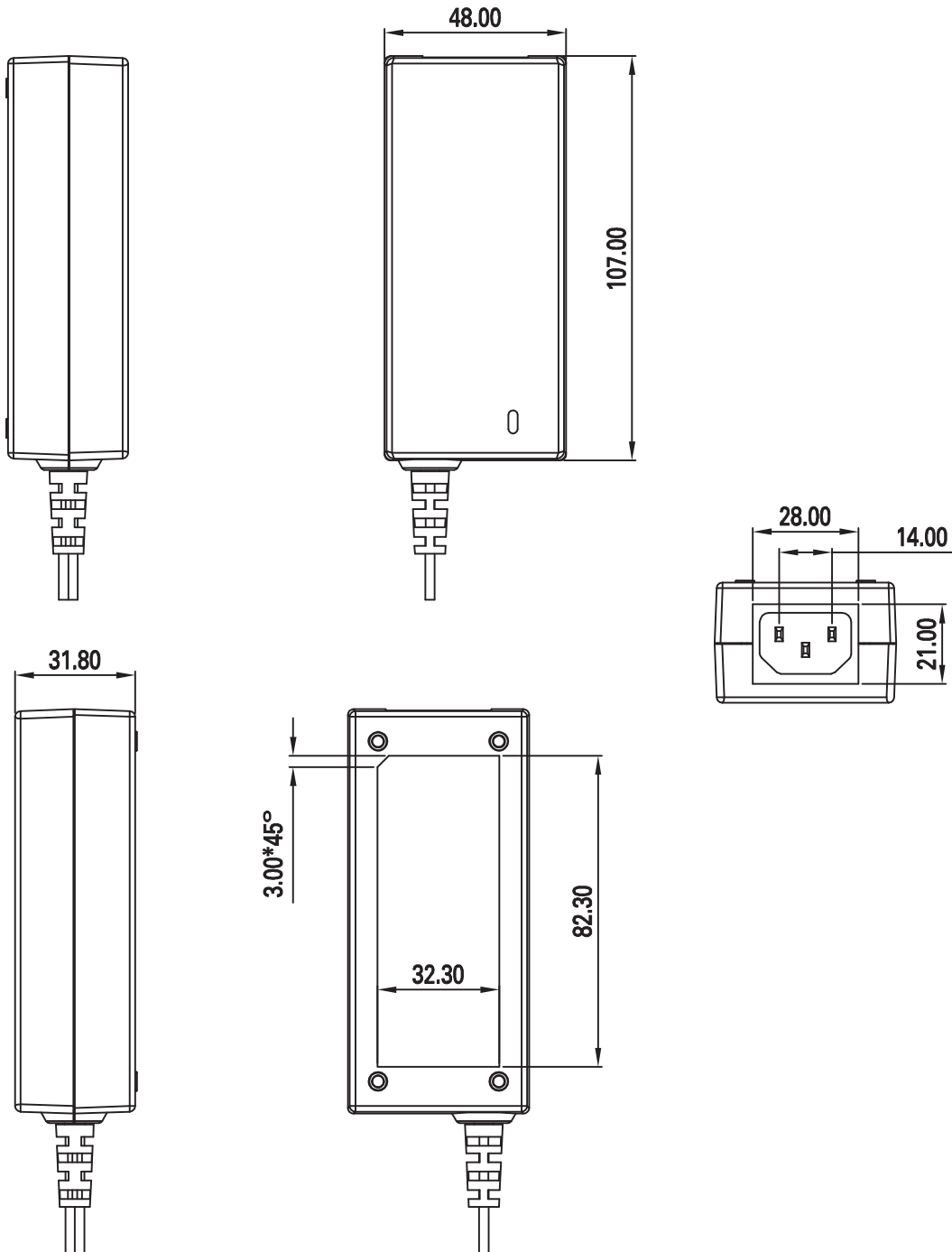

12. Label

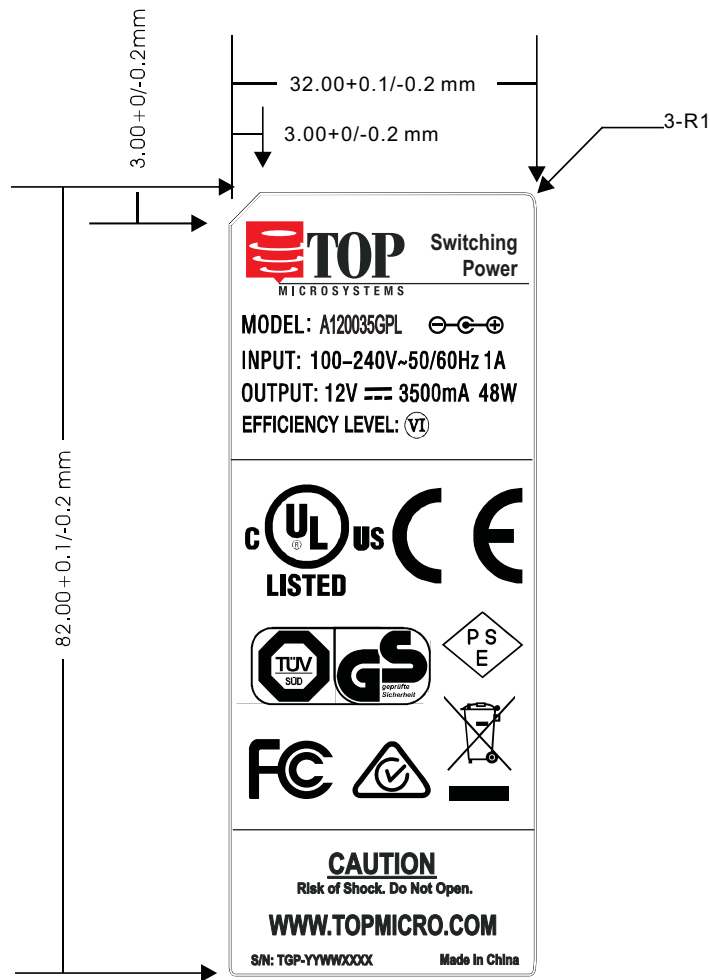

13. PE Bag

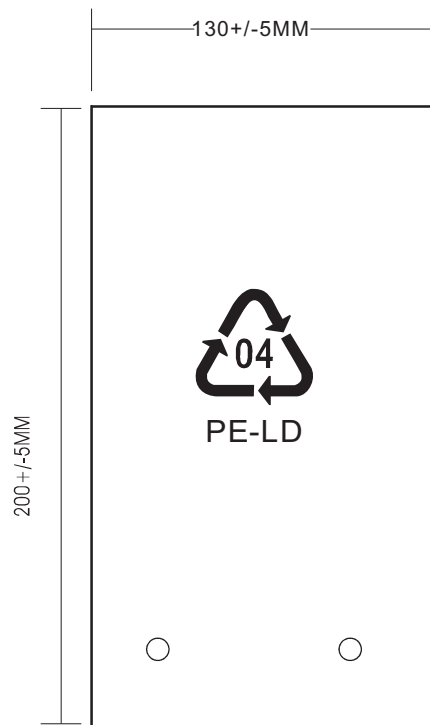

200X130MM, 0.04mmPE

14. Master Carton

