

SPECIFICATION

**Medical Grade
2"x4" Open Frame
Switching Power Supply**

**Universal AC Input
60W 12.0VDC 5.0A Output**

P/N: N1060PW-M12

*** Specification Approval ***

This specification (total 5 pages including cover page) in its entirety is approved by:

Company Name

Print Name

Signature

Date

Specification subject to change without prior notice.



3261 Keller St.
Santa Clara, CA 95054
Tel: 408-980-9813
Fax: 408-980-8626
Email: infor@topmicro.com

CONTENTS

1. SCOPE.....	<u>2</u>
2. INPUT REQUIREMENTS.....	<u>2</u>
3. OUTPUT CHARACTERISTICS.....	<u>2</u>
3.1 STATIC DC LOAD , RIPPLE & NOISE	<u>2</u>
3.2 HOLD UP TIME	<u>2</u>
3.3 OVERSHOOT AT TURN-ON/TURN-OFF	<u>2</u>
3.4 TEMPERATURE COEFFICIENT	<u>2</u>
4. PROTECTION	<u>3</u>
4.1 OVER VOLTAGE PROTECTION.....	<u>3</u>
4.2 SHORT CIRCUIT PROTECTION	<u>3</u>
4.3 OVER LOAD PROTECTION	<u>3</u>
5. ENVIRONMENT	<u>3</u>
5.1 OPERATING.....	<u>3</u>
5.2 SHIPPING AND STORAGE.....	<u>3</u>
6. SAFETY REQUIREMENTS.....	<u>3</u>
6.1 DIELECTRIC WITHSTAND	<u>3</u>
6.2 INSULATION RESISTANCE.....	<u>3</u>
7. ELECTROMAGNETIC COMPABILITY.....	<u>4</u>
7.1 FCC REQUIREMENTS.....	<u>4</u>
7.2 CE REQUIREMENTS.....	<u>4</u>
8. BURN-IN TEST	<u>4</u>
9. MECHANICAL DIMENSION	<u>4</u>

1. SCOPE

This specification describes the performance characteristics of a grounded, single phase, 60 Watts, Single Output Medical Power Supply defines the world wide safety requirements and EMC requirements.

2. INPUT REQUIREMENTS

Description	Min	Typical	Max.	Condition
Input Voltage	90VAC	115/230V	264VAC	Full Range : 50/60Hz
Input Current	-	-	2A	90 VAC 50Hz
Line Frequency	47Hz	50/60Hz	63Hz	-
Inrush Current	-	-	80A	230VAC Cold Start
Efficiency	-	80%	-	115VAC at full load
Leakage Current	-	-	300uA	264VAC

3. OUTPUT CHARACTERISTICS

3.1 STATIC DC LOAD , RIPPLE & NOISE

NOMINAL VOLTAGE	TOTAL REGULATION	OUTPUT CURRENT		RIPPLE & NOISE
		MIN.	MAX.	
+12V	±3%	0A	5A	120mV

NOTE : ⦿ 20MHz bandwidth ripple & noise is measured by using 0.1uF C.C. & 10uF/50V E.C. bypassed at the output connector.

⦿ Regulation shows the percentage of absolute value of nominal output voltage.

3.2 HOLD UP TIME

The power supply unit should maintain its proper output voltage within voltage specifications for at least 10 milliseconds after losing input power under the condition of typical input with full loading.

3.3 OVERSHOOT AT TURN-ON/TURN-OFF

Any overshoots during turn-on/turn-off should be less than +/-5% of the nominal output voltage values. No voltage of opposite polarity shall be present on any output during turn-on or turn-off.

3.4 TEMPERATURE COEFFICIENT

The temperature coefficient of all outputs is +/-0.05% per degree C maximum.

4. PROTECTION

4.1 OVER VOLTAGE PROTECTION

If any over voltage occurs, the power supply should not danger before any output exceeds its limit below :

NOMINAL VOLTAGE	VOLTAGE RANGE	
	FROM	TO
+12VDC	+13.2VDC	+15.6VDC

4.2 SHORT CIRCUIT PROTECTION

Short circuit occurred on output should not cause any damage to the power supply but shut down the power supply. The power supply will be automatically recovered after the short circuit being removed.

4.3 OVER LOAD PROTECTION

An over load protection will be effected when overloading reaches 120%~180% Max. load. The power supply will be automatically recovered after the overload being removed.

5. ENVIRONMENT

5.1 OPERATING

Temperature 0 to 50 degree centigrade
 Relative Humidity 20 to 90 percent, non-condensing

5.2 SHIPPING AND STORAGE

Temperature -10 to +70 degree centigrade

6. SAFETY REQUIREMENTS

The power supply must comply with UL 60601-1 / CSA C22.2 No.601.1-M90 / EN 60601-1 / IEC 660601-1 standards.

6.1 DIELECTRIC WITHSTAND

--- Primary to Secondary : 5765 VDC for 2 Sec.
 --- Primary to Frame Ground : 2160 VDC for 2 Sec.

6.2 INSULATION RESISTANCE

--- Primary to Secondary : 20 Meg. Ohms Min. 500 VDC.
 --- Primary to Frame Ground : 20 Meg. Ohms Min. 500 VDC.

7. ELECTROMAGNETIC COMPABILITY

Tests for conformance to this requirement will be performed with host system.

7.1 FCC Requirements

The power supply shall comply with the FCC part 18 limits.

7.2 CE Requirements

The power supply shall comply with the "Class B" requirements of EN60601-1-2 & EN55011 , EN61000-3-2 and EN61000-3-3.

8. BURN-IN TEST: 100% burn-in tested at max. load under 40 +/-5 degree centigrade.

9. MECHANICAL DIMENSION

Outside dimension: 101.6(L) X 50.8(W) X 30(H)mm

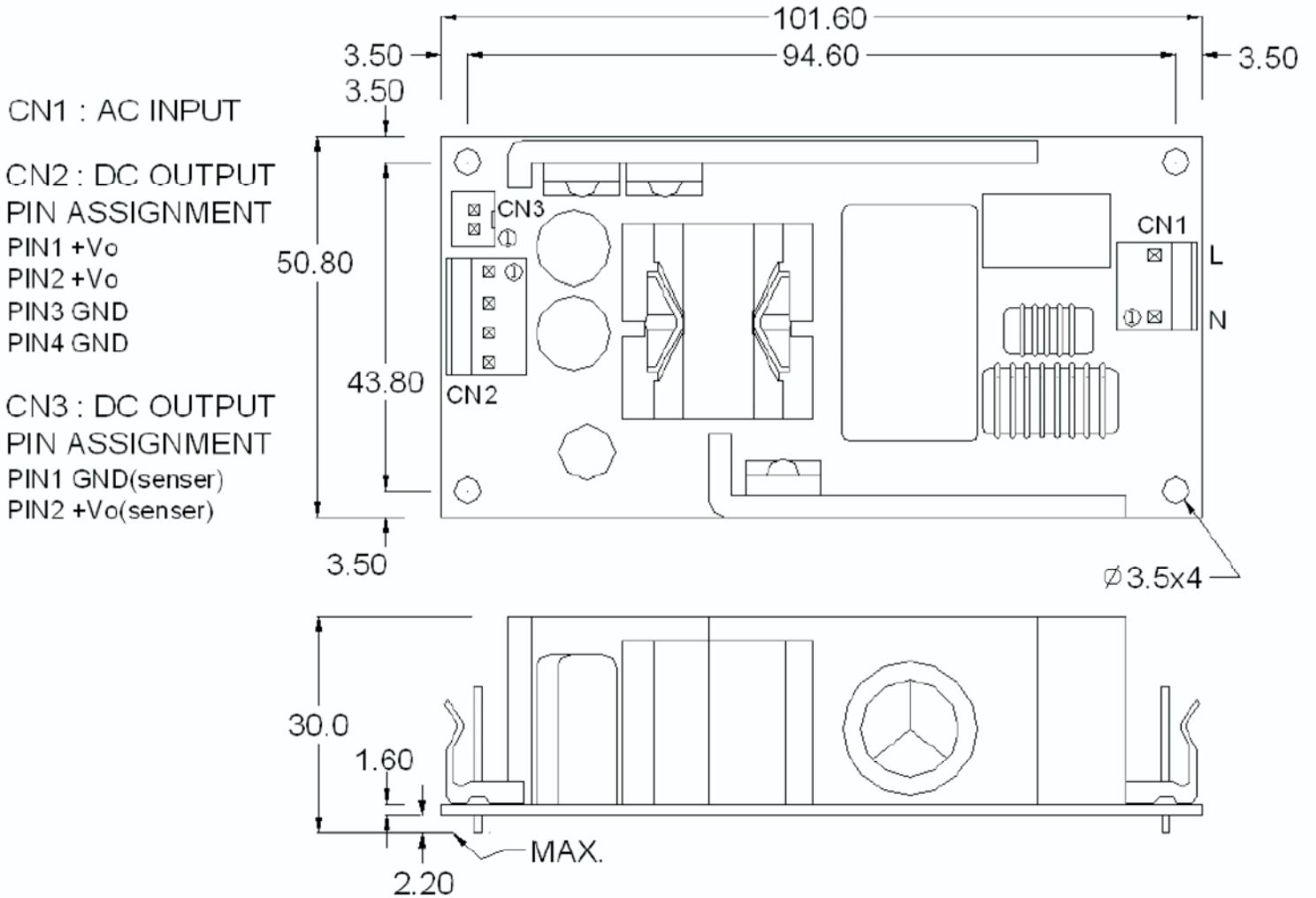

Dimension: L101.6 x W50.8 x H30mm

UNIT : mm