

SPECIFICATION

High Quality Switching Power Adapter (for use in U.S.A and Japan)

**Universal AC Input
2.4W 12VDC 0.2A**

P/N: W120002YF-UJ

**** Specification Approval****

This specification (total 10 pages including cover page) is approved in it's entirety by:

Company Name

Print Name

Signature

Date



3261 Keller St.
Santa Clara CA 95054
Tel: 1-408-980-9813
Fax: 1-408-980-8626
Email: infor@topmicro.com
Web: www.topmicro.com

CONTENTS

1. Specification.....	Page 3
2. Electrical Requirements.....	Page 3
3. Product and Test Requirements.....	Page 5
4. Output Cable and Plug.....	Page 6
5. Label.....	Page 7
6. Outside Dimensions.....	Page 8
7. Packing.....	Page 9
8. Electrical Test Report.....	Page 10

1. Specification

1.1 The purpose of this document is to specify the performance of the single output switching power adaptor.

1.2 This product is AC to DC power transfer device, it can provide for a **2.4W** single DC output.

1.3 The nominal external dimensions of the power adaptor are **63mm*44mm*29mm**

2. Electrical Requirements

2.1 Input Characteristic

2.1.1 Input Voltage

The rated input voltage is from 100V to 240V RMS; but the power adaptor shall be capable of supplying rated output power with maximum input range of 90V to 264V RMS.

MIN	NOMINAL	MAX	UNITS
90	100 – 240	264	Vrms

2.1.2 Input Frequency

The adaptor shall meet in all-applicable specifications with the input frequency range from 47 to 63Hz.

MIN	NOMINAL	MAX	UNITS
47	50 – 60	63	Hz

2.1.3 Input Current

The input current is less than **300mA** RMS at full load and input voltage range of 100VAC to 240VAC.

AC INPUT	MAX	UNITS
100-240	0.25	Ampere

2.1.4 Stand-by Power

The Stand-by power of the adaptor shall be less than **0.5Watts** at the input voltage range of 100VAC to 240VAC.

2.1.5 Input Surge Current

The input surge current is less than 30A at 120V and 40A at 240V input voltage for cold start.

AC INPUT	MAX	UNITS
120	30	Ampere
240	40	Ampere

2.2 Output Characteristic

2.2.1 Output Voltage and Output Power

The power adaptor provides one output: **12Volts DC**. The maximum continuous output powers Around **2.4Watts(12Vx0.2A)**

2.2.2 Efficiency

The efficiency of the power adaptor should be higher than **65%** at full rated load and any rated input voltage.

2.2.3 Output Voltage Range

The output voltage under all conditions of rated input voltages, input frequencies and output loads from minimum to maximum can remain the following limit:

Normal voltage	Regulation tolerance	Limit
12V	±5%	11.4~12.6V

(Note: The limit at no load is**12.6V** maximum and at full load is**11.4V** minimum.)

2.2.4 Output Current

The power adaptor shall have regulated DC output current of **0-0.2A** .

2.2.5 Hold Up Time

The power supply is capable of maintaining the output voltage as specified in section 2.1.1 for more than **10mSec** after remove input voltage that measured at full load.

2.2.6 Rise Time

The power supply shall have a start-up rise time of less than **100msec** to rise to within regulation limits for all DC outputs.

2.2.7 Line Regulation

Input voltage nominal and rated current, output voltage regulation **±1%**.

2.2.8 Load Regulation

Input voltage nominal and 0~rated output current, output voltage Regulation **±5%** .

2.2.9 Output Over Current Protection (OCP)

The output shall be protected against the over current conditions. It shall recover automatically when after removal of the over circuit. Power on reset is not required.

2.2.10 OVER-VOTAGE PROTECTION

7.5VDC maximum with ZENER clamp.

2.2.12 Short-Circuit Protection

The power supply shall withstand a continuous output short without damage.The short may be applied before power-up,or after power-up.The power supply shall resume normal operation after the short is removed.

2.2.13 Output Ripple and Noise voltage

The specified noise & ripple are measured differently at the supply using maximum loads that are each shunted by 47uF electrolytic capacitor and 0.1uF ceramic capacitor. Measurements shall be made by using a storage Oscilloscope having a bandwidth of 20MHz.and at nominal AC input voltage.

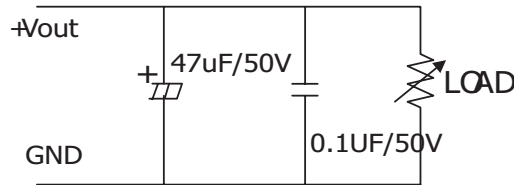

AC input voltage	Rated output	Ripple & Noise	Bandwidth
100V-240V AC	12V/0.2A	Less than 120mVp-p	20MHz

3. Product and Test Requirements

3.1 Withstand Voltage

When AC voltage of **1.0KV** is applied for **60 seconds** (or 1.2KV is applied for 2 seconds) between the input and output and between the input and housing, the current sensitivity is output and greater than 5mA. After this test, the adaptor shall exhibit no electrical and mechanical abnormalities.

3.2 Insulation Resistance

The insulation resistance is more than **10Mohms** at between input-plug and output-plug with 500VDC voltage.

3.3 Vibration Test

Frequency=10-55-10Hz, Amplitude 1.5mm, X-Y-Z direction, 30 minutes each direction. Under non-operating status, meet specification after test.

3.4 Environmental Requirements

3.4.1 Operating and Storage Temperature and Humidity

a. Operating

Operating temperature range: from 0 degree C to 40 degree C

Operating humidity range: from 20%R.H. to 90%R.H..

b. Storage

Storage temperature range: from -20 degree C to 70 degree C

Storage humidity range: from 5%R.H. to 95%R.H.

3.4.2 Drop Test

The adaptor shall exhibit no abnormality in mechanical or electrical performance when it is dropped three times to hardwood from a height of 100cm, with each of the three sides of the adaptor striking the hardwood each time. Small nicks or slight deformations in the corners of the housing (will be accepted with 5mm Max. of nicks or 5mm Max. diameter of each corner), or cracks not penetrating the inside may be accepted.

3.4.3 Tensile strength

Fixing either of the main body shall make the test or the plug and applying a 20N load to the other part for 60seconds. No connections shall be broken and the cord shall not be removed.

3.4.4 Bending test

The test mode as follows: as shown on figure below, fix the main body and plug of the adapter, and apply a load of 200g to the other ends. Turn the cable connected to each by ±45 degrees around the connection. Carry out this process 500 times at a rate of 40 times per minute (a bending of 90 degrees shall be counted as one process) in each direction.

The cable wires shall no be broken after this test.

3.5 Safety

The power supply must be certified under following international standards.

	Country	Certified	Standard
UL	USA	Yes	UL60950
PSE	Japan	Yes	J60950

3.6 EMI Standards

The power supply meets the radiated and conducted emission requirements for EN55022 CLASS B.

3.7 EMS Standards

3.7.1 EN61000-4-2 Electrostatic Discharge (ESD)

Static – discharge test by contact or air should be conducted with Static – discharge teeter, energy storage capacitance of 150pF, and discharge resistance of 330? 8KV air discharge, 4KV contact discharge, Performance Criterion B.

3.7.2 EN61000-4-5 Lightning Surge Attachment

Lightning Surge voltage of differential and command modes shall be applied across . AC input lines and across input frame ground.
Power Line to Line:1KV.
Performance Criterion B.

3.8 Leakage Current

Leakage Current shall not exceed **0.25mA** max.

3.9 Burn-In

The power supply will be performed a minimum for **2 hours** Burn-in at 40C ±5 under 80% load to full load on all power supplies.

4. Output Cable and Plug

2468 #24AWG 1830mm DC 5.5x2.1x10mm Center-positive

5. Label

1. Material:
2. Color: White background with black font.
3. Thickness: 0.15mm.

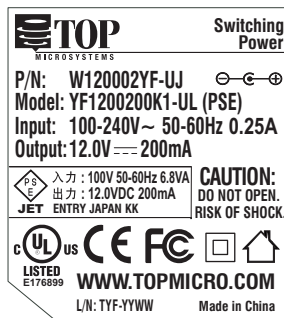

6. Outside Dimensions

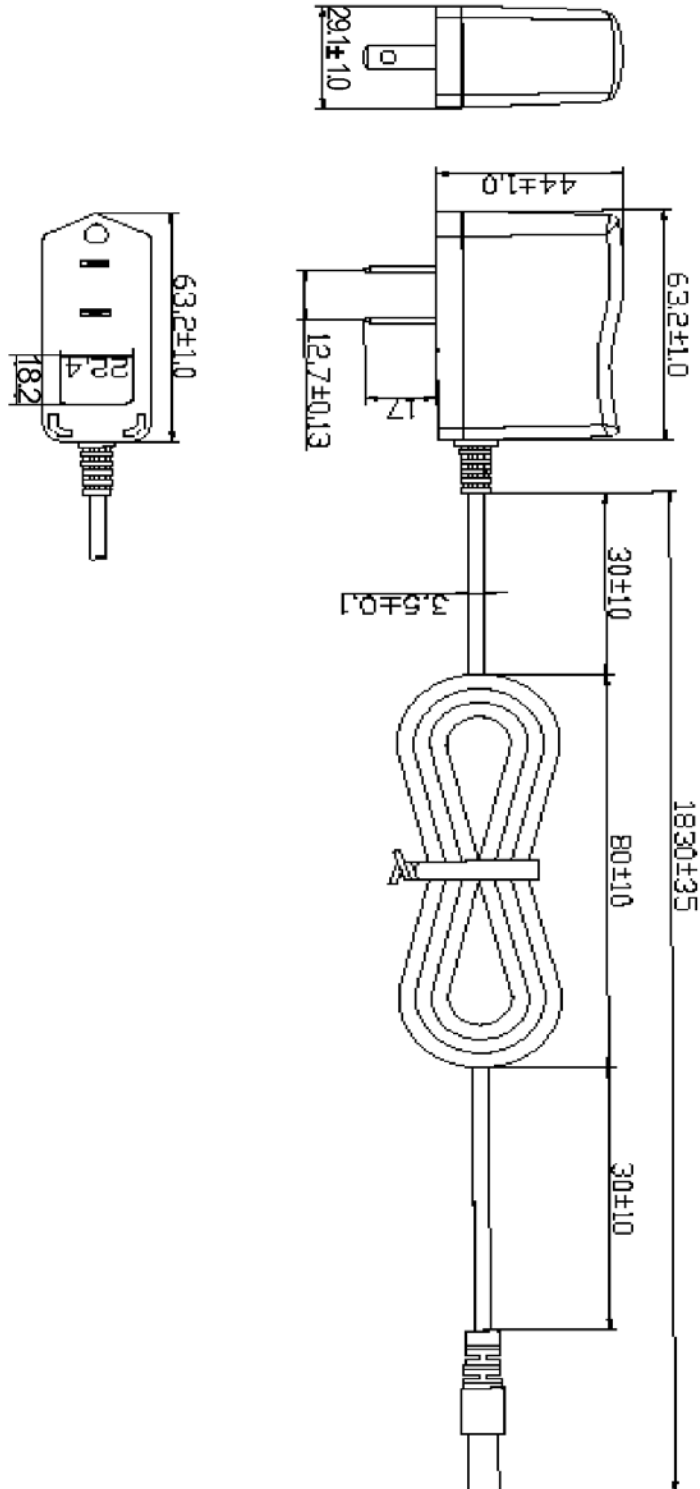

7. Packing

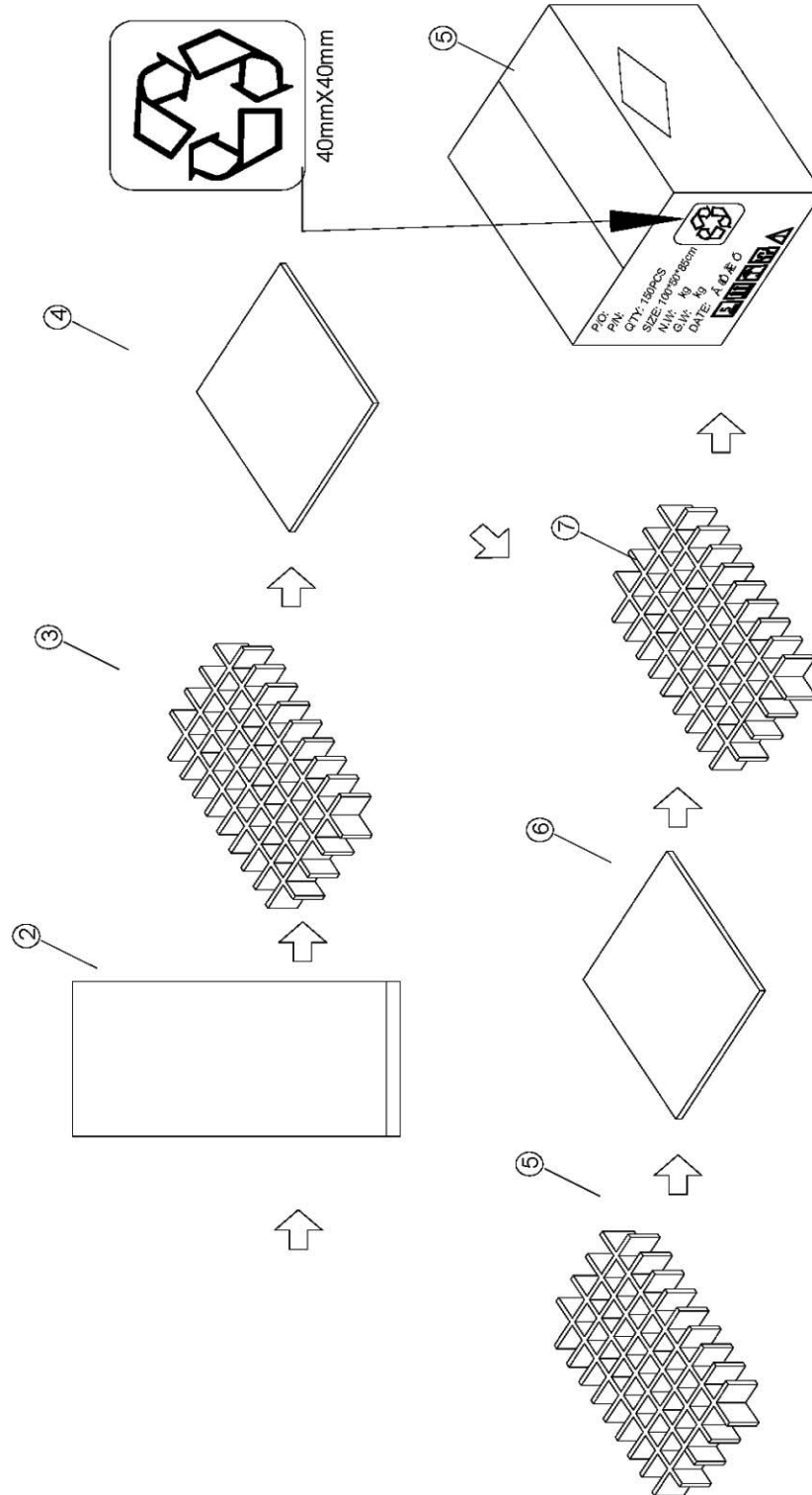

8. Electrical Test Report

NO	TEST ITEM	TEST CONDITION	UNIT	TEST SPEC/SAMPLE READING					STANDARD SPEC	JUDGE
				1	2	3	4	5		Pass/Fail
1	Unload Input Current	Vin 100Vac 60Hz Io=0	mA	6.00	5.00				20mA	Pass
2	Unload Input Power	Vin 100Vac 60Hz Io=0	W	0.18	0.18				0.5W	Pass
3	Rated Load Input Current	Vin 100Vac 60Hz Io=Rated Current	A	0.08	0.08				0.3A	Pass
4	Rated Load Input Power	Vin 100Vac 60Hz Io=Rated Current	W	3.60	3.70				10.0W	Pass
5	Unload Output Voltage	Vin 100Vac 60Hz Io=0	V	12.17	12.15				12.0±5%	Pass
6	Rated Load Output Voltage	Vin 100Vac 60Hz Io=Rated Current	V	11.95	11.93				12.0±5%	Pass
7	Output Ripple Noise Voltage	Vin 100Vac 60Hz Io=Rated Current	mVp-p	65.0	70.0				100 mVp-p	Pass
8	Efficiency	Vin 100Vac 60Hz Io=Rated Current	%	66.00%	65.00%				65.0%	Pass
9	Short-circuit Input Power	Vin 100Vac 60Hz	W	0.22	0.25				3.0W	Pass
10	Power Factor	Vin 100Vac 60Hz Io=Rated Current	-	0.38	0.42				0.3	Pass
11	Load Regulation	Vin 100Vac 60Hz	%	4.00%	5.00%				6%	Pass
12	Unload Input Current	Vin 240Vac 50Hz Io=0	mA	5.00	4.00				20mA	Pass
13	Unload Input Power	Vin 240Vac 50Hz Io=0	W	0.30	0.30				0.5W	Pass
14	Rated Load Input Current	Vin 240Vac 50Hz Io=Rated Current	A	0.04	0.05				0.3A	Pass
15	Rated Load Input Power	Vin 240Vac 50Hz Io=Rated Current	W	4.00	3.90				10.0W	Pass
16	Unload Output Voltage	Vin 240Vac 50Hz Io=0	V	12.18	12.15				12.0±5%	Pass
17	Rated Load Output Voltage	Vin 240Vac 50Hz Io=Rated Current	V	11.95	11.93				12.0±5%	Pass
18	Output Ripple Noise Voltage	Vin 240Vac 50Hz Io=Rated Current	mVp-p	70.0	72.0				100 mVp-p	Pass
19	Efficiency	Vin 240Vac 50Hz Io=Rated Current	%	63.00%	62.00%				60.0%	Pass
20	Short-circuit Input Power	Vin 240Vac 50Hz	W	0.47	0.45				3.0W	Pass
21	Power Factor	Vin 240Vac 50Hz Io=Rated Current	-	0.43	0.41				0.3	Pass
22	Load Regulation	Vin 240Vac 50Hz	%	4.00%	5.00%				6%	Pass
23	Line Regulation	Vin 100Vac~240Vac Io=Rated Current	%	0.13%	0.15%				1%	Pass
24	Drop Test	OK								Pass
25	Hi-pot Test	1000Vac, 1 Minute, Cut off current 5mA.								Pass
26	Burn In Test	45C Ambient, 80% load, 45min. ON and 15min. OFF, Burrn-in 2Hrs.								Pass